



**somfy**

**Glydea® ULTRA 60 Motor RTS**

**Glydea® ULTRA 35 Motor RTS**

# Benefits

## Comfort & Convenience

- Reduce glare or enjoy privacy using the quietest motor solution available.
- Strong traversing capacity offers light, fluid movement for heavier curtains.
- Use natural voice commands to control RTS motorized solutions by adding TaHoma.

## Energy Saving

- Reduce energy costs automatically by adding sensors or timers.
- Protect valuable furnishings from the sun's damaging UV rays.

# Glydea® ULTRA 60

## Technical Specifications

### Motor part numbers

**Glydea® ULTRA 60 RTS motor**  
(with 10' cable and molded NEMA plug)

**Glydea® ULTRA 60 DCT motor**  
(with 10' cable and molded NEMA plug)

**Glydea® ULTRA 60 Wired motor**  
(5' long without plug)

### Features overview

	Glydea® ULTRA 60
<b>Motor unit main features</b>	
Soft start	✓
Manual operation	✓
Automatic limits on end stop	✓
Soft stop	✓
Intermediate position	✓
Touch motion with 2 sensitivity settings	✓
Adjustable limits	✓
Speed control & adjustment	✓
<b>Control options</b>	
Dry contact input via RJ12 Connector	✓
Dry contact individual, group and master control	✓
Radio Technology Somfy® RTS	✓
SDN RS485 digital technology (two-way communication)	✓
Zigbee® (two-way communication) (DCT only)	✓
Tandem alternative	✓
Sun control	✓
Timer control	✓
<b>Installation and setting features</b>	
Settings with buttons on motor unit	✓
Setting with 3 normally open dry contact switch	✓
LED indicators	✓
Motor unit direction change	✓
Factory reset	✓
Inverse (top mount) mounting	✓
<b>Tracks/Drapery Types</b>	
One-way opening	✓
Center opening	✓
Asymmetric	✓
Multiple	✓
Pinch pleat	✓
Ripplefold® with overlap arm	✓
Ripplefold® with butt arm	✓
Accordia®	✓

### Motorized track main characteristics

	Glydea® ULTRA 60
Power Supply	120V AC 50/60 HZ
Amperage	0.8 A
Average linear speed	Silent Mode: 2.95 in./s (7.5 cm/s) Standard Mode: 4.95 in./s -7.86 in./s (12.5 cm/s-20 cm/s)
Power consumption	96W (standby <1W)
Power cable type	3-wire cable with molded NEMA plug 4-wire cable (wired version only)
Control connector type (Dry Contact)	RJ12
DCT control circuit voltage	3.3 VDC
Motor sound level	<38 dBA at silent mode
Certifications	c TUV us, CE
Track maximum length	36 ft. (10.9 m)
Maximum number of splices	2
Minimum bending radius	11.8 in. (30 cm)
Minimum curving radius	118 in. (300 cm)
Side opening max weight	132 lbs. 60 kg.
Center opening max weight	132 lbs. 60 kg.
Tandem alternative (see pages 23, 24, 26)	264 lbs./ 120 kgs. 72 ft./ 21.8 m

### Motor dimensions

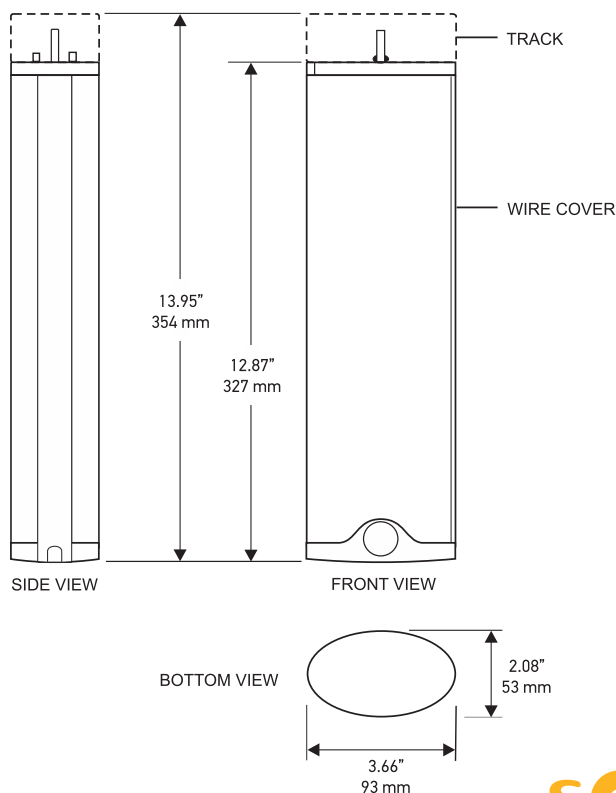

# Glydea® ULTRA 35

## Technical Specifications

### Motor part numbers

**Glydea® ULTRA 35 RTS motor**  
(with 10' cable and molded NEMA plug)

**Glydea® ULTRA 35 DCT motor**  
(with 10' cable and molded NEMA plug)

**Glydea® ULTRA 35 Wired Motor**  
(5' long without plug)

### Features overview

	Glydea® ULTRA 35
<b>Motor unit main features</b>	
Soft start	✓
Manual operation	✓
Automatic limits on end stop	✓
Soft stop	✓
Intermediate position	✓
Touch motion with 2 sensitivity settings	✓
Adjustable limits	✓
Speed control & adjustment	✓
<b>Control options</b>	
Dry contact input via RJ12 Connector	✓
Dry contact individual, group and master control	✓
Radio Technology Somfy® RTS	✓
SDN RS485 digital technology (two-way communication)	✓
Zigbee® (two-way communication) (DCT only)	✓
Tandem alternative	✓
Sun control	✓
Timer control	✓
<b>Installation and setting features</b>	
Settings with buttons on motor unit	✓
Setting with 3 normally open dry contact switch	✓
LED indicators	✓
Motor unit direction change	✓
Factory reset	✓
Inverse (top mount) mounting	✓
<b>Tracks/Drapery Types</b>	
One-way opening	✓
Center opening	✓
Asymmetric	✓
Multiple	✓
Pinch pleat	✓
Ripplefold® with overlap arm	✓
Ripplefold® with butt arm	✓
Accordia®	✓

### Motorized track main characteristics

	Glydea® ULTRA 35
Power Supply	120V AC 50/60 HZ
Amperage	0.8 A
Average linear speed	Silent Mode: 2.95 in./s (7.5 cm/s) Standard Mode: 4.95 in./s -7.86 in./s (12.5 cm/s-20 cm/s)
Power consumption	96W (standby <1W)
Power cable type	3-wire cable with molded NEMA plug 4-wire cable (wired version only)
Control connector type (Dry Contact)	RJ12
DCT control circuit voltage	3.3 VDC
Motor sound level	<38 dBA at silent mode
Certifications	c TUV us, CE
Track maximum length	32 ft. (9.7 m)
Maximum number of splices	2
Minimum bending radius	11.8 in. (30 cm)
Minimum curving radius	118 in. (300 cm)
Side opening max weight	77 lbs. 35 kg.
Center opening max weight	77 lbs. 35 kg.
Tandem alternative (see pages 23, 24, 26)	154 lbs./ 70 kgs. 64 ft./ 19.4 m

### Motor dimensions

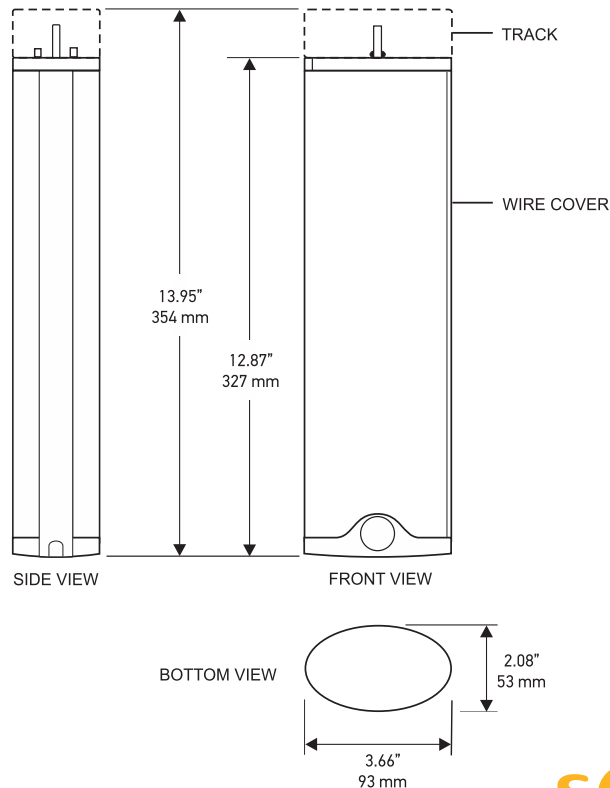



**somfy**

## Irismo™ 45 WireFree RTS (with rechargeable battery)

# Benefits

### Comfort & Convenience

- Perfect solution to reduce glare or create instant privacy.
- Open or close draperies with the simple press of a button.
- Superior, reliable performance.
- Smartphone/tablet app provides control from virtually anywhere.
- Use natural voice commands to control RTS motorized solutions by adding TaHoma.

### Energy Savings

- Reduce energy consumption up to 40%.
- Protect valuable furnishings from harmful UV rays.
- Add optional timers or sensors to provide automatic control.

# Irismo™ 45 WireFree RTS

## Technical Specifications

### Motor part numbers

#### Irismo™ 45 WireFree RTS

### Features overview

	Irismo™ 45 WireFree RTS
<b>Motor unit main features</b>	
Soft start	✓
Soft stop	✓
Manual operation	✓
Automatic limits on end stop	✓
Intermediate position	✓
Touch motion with 2 sensitivity settings	✓
Adjustable limits	✓
Speed control & adjustment	✓
<b>Control options</b>	
Radio Technology Somfy® RTS	✓
Tandem alternative	✓
Sun control	✓
Timer control	✓
<b>Installation and setting features</b>	
LED indicators	✓
Audible sound Indicator	✓
Motor unit direction change	✓
Factory reset/programming button	✓
Inverse mounting (top mount)	✓
<b>Tracks/Draper Types</b>	
One-way opening	✓
Center opening	✓
Asymmetric	✓
Pinch pleat	✓
Ripplefold® with overlap arm	✓
Ripplefold® with butt arm	✓
Accordia®	✓

### Motorized track main characteristics

	Irismo™ 45 WireFree RTS
Power supply	25.9V DC
Average linear speed	4.9 in./s - 7.86 in./s 12.5 cm/s - 20 cm/s
Rechargeable (Li-ion) battery capacity	3200 mAh
Motor sound level	<44 dBA
Certifications	CE
Track maximum length	33 ft. (10 m)
Maximum number of splices	2
Minimum bending radius	11.8 in. (30 cm)
Minimum curving radius	118 in. (300 cm)
Side opening max weight	99 lbs. (45 kg)
Center opening max weight	99 lbs. (45 kg)
Tandem alternative (see pages 23, 24, 26)	198 lbs. (90 kg)

### Motor dimensions

